

# 睿智X3000系列

适用于机器视觉、运动控制、智能装备、自动化设备、人工智能等领域。

ReiZ X30 产品参数						
性能参数	产品名称	ReiZ 睿智 X3000				
	订货号(可选)	X3000-AXXX	X3000-DXXX	X3000-EXXX	X3000-CXXX	
	颜色	深灰				
	操作系统(可选)	Windows 10, Ubuntu, etc.				
	处理器(可选)	Intel® 12 <sup>th</sup> Core™ i7 12700 2.1GHz, 可睿频至4.9GHz, 25M Cache, TDP 65W Intel® 12 <sup>th</sup> Core™ i5 12400 2.5GHz, 可睿频至4.4GHz, 18M Cache, TDP 65W Intel® 12 <sup>th</sup> Core™ i5 12500 3.0GHz, 可睿频至4.6GHz, 18M Cache, TDP 65W Intel® 12 <sup>th</sup> Core™ i3 12100 3.3GHz, 可睿频至4.3GHz, 12M Cache, TDP 60W Intel® 12 <sup>th</sup> Core™ i5 12500T 2.0GHz, 可睿频至4.4GHz, 18M Cache, TDP 35W Intel® 12 <sup>th</sup> Core™ i3 12300T 2.3GHz, 可睿频至4.2GHz, 12M Cache, TDP 35W Intel® 12 <sup>th</sup> Core™ i3 12100T 2.2GHz, 可睿频至4.1GHz, 12M Cache, TDP 35W				
	主板芯片组	Intel H610, Intel Q670(可选)				
	内存	DDR4 3200Mhz Up to 32GB, 2 x 260-pin SO-DIMM				
	存储(可选)	1 x M.2 + 1 x 2.5" SATAIII HDD/SSD(可选)				
接口参数	显示	1 x DP: up to 4096 x 2610@30Hz, 1 x HDMI :up to 4096 x 2610@30Hz				
	网络(可选)	LAN1: Intel i219LM LAN2/3: Intel i210	LAN1: Intel i219LM LAN2/3/4/5: Intel i210	LAN1: Intel i219LM LAN2/3/4/5/6/7: Intel i210	LAN1: Intel i219LM LAN2/3: Intel i210	
	I/O 接口	COM	2 x COM(RS-232/485) 4 x COM(RS-232)	2 x COM(RS-232/485) 4 x COM(RS-232)	2 x COM(RS-232/485) 2 x COM(RS-232)	2 x COM(RS-232/485) 4 x COM(RS-232)
		USB	2 x USB2.0, 4 x USB3.0(内部3个USB2.0)			
		DIO	16路光耦隔离DIO(可选)			
		开关	物理开关			
	Audio	1 x Line out(可选)				
扩展槽	1 x PCIe X16, 1 x PCIe X4			1 x PCIe X16, 2 x PCI		
供电参数	电压范围	12V DC, 过压, 接反保护				
	电源适配器	220VAC输入 12V/12.5A输出电源适配器(可选)				
基础参数	外观尺寸	208(宽) x 133/153(高) x 200(深)mm				
	净重	3.3Kg				
	整机功耗	最高功耗100W				
	散热方式	高性能铜管导热和面积铝材质结合散热				
	安装方式	嵌入式				
	工作环境	-10~50℃ (选配固态硬盘), 0~40℃ (2.5" 笔记本硬盘)				
存储温度	-20~70℃					

备注：具体订货号详情请咨询销售专员

# 睿智X3000系列 I/O接口图

## X3000-A

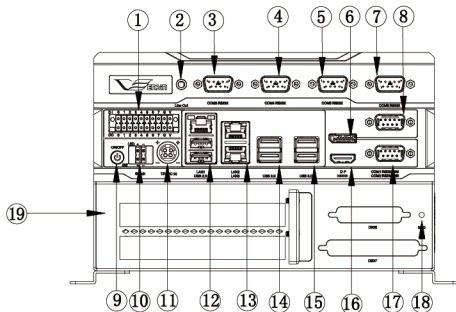

- |                                  |                  |                   |
|----------------------------------|------------------|-------------------|
| ① 16路DIO (可选)                    | ② Line Out       | ③ COM3 RS232      |
| ④ COM4 RS232                     | ⑤ COM5 RS232     | ⑥ DP              |
| ⑦ COM6 RS232                     | ⑧ COM1 RS232/485 | ⑨ ON/OFF          |
| ⑩ LED & SW                       | ⑪ 12VDC IN       | ⑫ LAN1 & USB2.0*2 |
| ⑬ LAN2 & LAN3                    | ⑭ USB3.0*2       | ⑮ USB3.0*2        |
| ⑯ HDMI                           | ⑰ COM2 RS232/485 | ⑱ GND             |
| ⑲ 扩展槽: 1 x PCIE X16, 1 x PCIE X4 |                  |                   |

## X3000-D

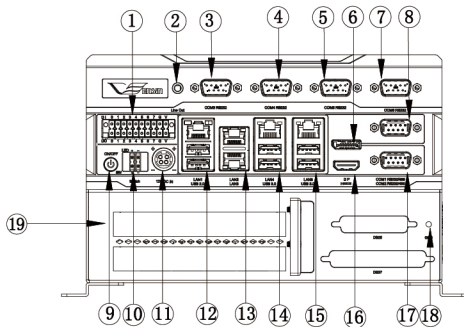

- |                                  |                   |                   |
|----------------------------------|-------------------|-------------------|
| ① 16路DIO (可选)                    | ② Line Out        | ③ COM3 RS232      |
| ④ COM4 RS232                     | ⑤ COM5 RS232      | ⑥ DP              |
| ⑦ COM6 RS232                     | ⑧ COM1 RS232/485  | ⑨ ON/OFF          |
| ⑩ LED & SW                       | ⑪ 12VDC IN        | ⑫ LAN1 & USB2.0*2 |
| ⑬ LAN2 & LAN3                    | ⑭ LAN4 & USB3.0*2 | ⑮ LAN5 & USB3.0*2 |
| ⑯ HDMI                           | ⑰ COM2 RS232/485  | ⑱ GND             |
| ⑲ 扩展槽: 1 x PCIE X16, 1 x PCIE X4 |                   |                   |

## X3000-E

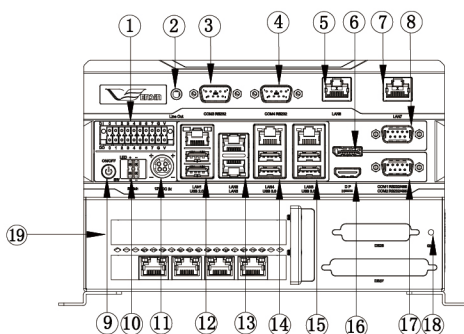

- |                                  |                   |                   |
|----------------------------------|-------------------|-------------------|
| ① 16路DIO (可选)                    | ② Line Out        | ③ COM3 RS232      |
| ④ COM4 RS232                     | ⑤ LAN6            | ⑥ DP              |
| ⑦ LAN7                           | ⑧ COM1 RS232/485  | ⑨ ON/OFF          |
| ⑩ LED & SW                       | ⑪ 12VDC IN        | ⑫ LAN1 & USB2.0*2 |
| ⑬ LAN2 & LAN3                    | ⑭ LAN4 & USB3.0*2 | ⑮ LAN5 & USB3.0*2 |
| ⑯ HDMI                           | ⑰ COM2 RS232/485  | ⑱ GND             |
| ⑲ 扩展槽: 1 x PCIE X16, 1 x PCIE X4 |                   |                   |

## X3000-C

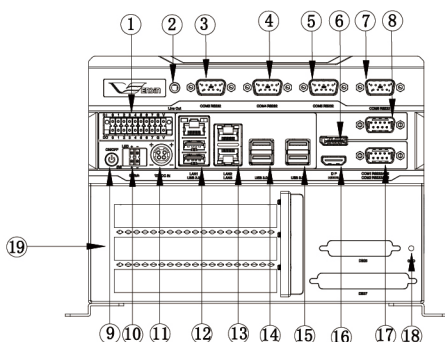

- |                              |                   |                   |
|------------------------------|-------------------|-------------------|
| ① 16路DIO (可选)                | ② Line Out        | ③ COM3 RS232      |
| ④ COM4 RS232                 | ⑤ COM5 RS232      | ⑥ DP              |
| ⑦ COM6 RS232                 | ⑧ COM1 RS232/485  | ⑨ ON/OFF          |
| ⑩ LED & SW                   | ⑪ 12VDC IN        | ⑫ LAN1 & USB2.0*2 |
| ⑬ LAN2 & LAN3                | ⑭ LAN4 & USB3.0*2 | ⑮ LAN5 & USB3.0*2 |
| ⑯ HDMI                       | ⑰ COM2 RS232/485  | ⑱ GND             |
| ⑲ 扩展槽: 1 x PCIE X16, 2 x PCI |                   |                   |

# 睿智X3000系列 产品尺寸图

## X2000 产品尺寸图

外观尺寸：208(宽)\*133(高)\*202(深)mm (不含支架)

安装尺寸：222(宽)\*160(高)mm

螺丝尺寸：M4

